



AT20 Online Dual-spectrum Thermal Camera User Manual V1.0.6



IRay Technology Co., Ltd.

www.infiray.com

Explore And Perceive The Future

Introduction to IRay Technology

IRay Technology Co., Ltd. concentrates on developing infrared thermal imaging technologies and manufacturing relevant products, with completely independent intellectual property rights. IRay is committed to providing global customers with professional and competitive infrared thermal imaging products and solutions. The main products include IRFPA detectors, thermal imaging modules, and terminal thermal imaging products.

With R&D personnel accounts for 48% of all employees, 662 intellectual property projects in terms of IRay have been authorized and accepted: 522 patented technologies authorized and accepted in China (including those for integrated circuit chips, MEMS sensors design and manufacture, Matrix III image algorithms and intelligent precise temperature measurement algorithms, etc.); 16 patented technologies authorized and accepted overseas; 86 software copyrights; and 38 integrated circuit layout designs.

IRay products have been applied in various fields, including epidemic prevention and control, industrial thermography, security and fire control, night vision observation, automatic driving, Internet of Things, AI, and machine vision.

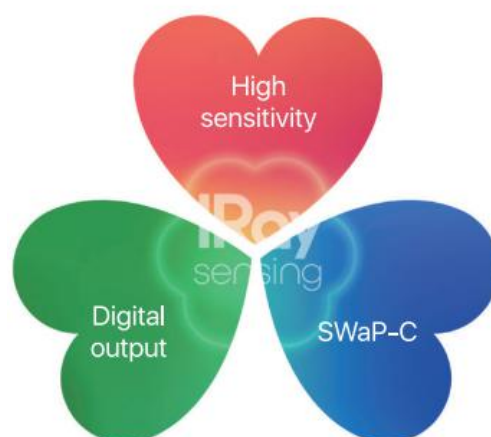

Table of Contents

1.Legal Disclaimer.....	1
1.1 Legal Disclaimer.....	1
1.2 Copyright.....	1
1.3 Quality Assurance.....	1
2.Safety Information.....	2
3.Notice to user.....	3
3.1 Calibration.....	3
3.2 Accuracy.....	3
3.3 Video Teaching.....	3
3.4 Documentation Update.....	3
4.Customer Help.....	3
4.1 FAQ.....	3
4.2 Download.....	3
5.Product Introduction.....	4
6.Product Figure and Explanation.....	5
7.Quick Start Guide.....	6
8.Product and Accessories List.....	7
9.Mechanical Installation.....	8
9.1 Installing Shells with Screws.....	9
9.1.1 Installing Front Shell.....	9
9.1.2 Installing Rear Shell.....	9
9.2 Front Mounting.....	10
9.3 Rear Mounting.....	11
10.Alarm Input and Output.....	12
10.1 Alarm Input.....	12
10.2 Alarm Output.....	12
11.Protocol Introduction.....	13
11.1 Modbus TCP.....	13
11.2 MQTT.....	13
12.Protocol Introduction.....	21
12.1 Modbus TCP.....	21
13.Technical Data.....	22
14.Pin Configuration for Interfaces.....	27
14.1 Ethernet Pin Configuration (8pin).....	27
14.2 Power Pin Configuration (12pin).....	28
15.Mechanical Drawings.....	29

16.Common Troubleshooting.....	30
17. Download Software and Update Firmware.....	31
17.1 Download Software.....	31
17.2 Update Firmware.....	31
18.Cleaning Thermal Camera.....	32
18.1 Cleaning Camera Housing, Cables and Other Items.....	32
18.2 Cleaning Infrared Lens.....	33
Appendix A Emissivity of Common Materials.....	34

1. Legal Disclaimer

1.1 Legal Disclaimer

The thermal cameras manufactured by IRAY TECHNOLOGY are warranted for a period of two-year and the accessories are warranted for a period of three-month from the delivery date of the original purchase, provided such products have been under normal storage, use and maintenance.

This warranty extends only to the original purchaser and is not transferable. It is not applicable to any product that has been subjected to misuse, neglect, accident or abnormal conditions of operation.

In the case of a defect in a product covered by this warranty, the product must not be further used or maintained in order to prevent additional damage. The purchaser shall promptly report any defect to IRAY TECHNOLOGY or this warranty will not apply.

IRAY TECHNOLOGY will, at its option, repair or replace any such defective product free of charge if, upon inspection, the product or accessories prove to be defective, the user can contact with after-sales service department of IRAY TECHNOLOGY within the said warranty period.

1.2 Copyright

©IRay Technology Co., Ltd. 2020. All right reserved worldwide. All contents in this manual, including words, pictures, images, etc., belong to IRAY TECHNOLOGY CO., LTD. (Hereinafter referred to as "THE COMPANY" or "IRAY TECHNOLOGY"). No part of the manual, in whole or in parts, may be copied, photocopied, translated, or transmitted without the prior written permission of IRAY TECHNOLOGY.

This manual is used as a guide. The photos, graphics, diagrams and illustrations provided in the manual are only used to explain, which may be different from the specific product. Please refer to the real object. We try our best to make sure the contents in this manual are accurate. We do not provide any representations or warranties in this manual.

IRAY TECHNOLOGY reserve the right to update the manual. If you need the latest version of this manual, please contact us. It is recommended that you use this manual with the guidance of professionals.

1.3 Quality Assurance

The Quality Management System under which these products are developed and manufactured has been certified in accordance with the ISO 9001 standard.

We reserve the right to make changes and improvements on any of the products without prior notice.

2.Safety Information

WARNING

- 1.Before using the cleanser, make sure you read all applicable material safety data sheets (MSDS) and warning labels on cleanser containers.
- 2.Do not use too long screws when installing the front/rear mounting bracket, which may damage the thermal camera.
- 3.It is prohibited to place the product in a high temperature above 70°C or in a low temperature below-45 °C.
- 4.It is forbidden to disassemble or refit the infrared thermal camera at will.

CAUTION

- 1.No matter there is a lens cover or not, do not point the infrared thermal camera towards strong light or equipment with laser radiation. This will affect the accuracy of the thermal camera and even damage the detector in the thermal camera.
- 2.Do not use the product under conditions that doesn't match the environmental requirements. For specific use environment requirements, see the product parameter table.
- 3.Do not apply solvents or equivalent liquids to the camera, the cables, or other items.
- 4.Be careful when you clean the infrared lenses. The lens has an anti-reflective coating which is easily damaged. Damage to the infrared lens can occur with too much force or cleaning with rough objects such as tissues.

3. Notice to user

3.1 Calibration

Annual calibration to the thermal camera is recommended to ensure the accuracy of temperature measurement, either through IRAY TECHNOLOGY or third-party organizations.

3.2 Accuracy

For accurate measurement, it's recommended that you use the thermal camera after it is stable for 30 minutes.

3.3 Video Teaching

You can search for mount and use videos from our website.

3.4 Documentation Update

Our manuals are updated several times per year, and we also issue product-critical notifications of changes on a regular basis. Please visit our website to access the latest manuals and notifications.

4. Customer Help

4.1 FAQ

You can find answers to FAQ about this model on the service support page of our official website.

4.2 Download

You can download the following contents from our website: www.infiray.com

Product Documentation

Client Software

Video Teaching Courses

5.Product Introduction



Main Features	Accurate temperature measurement
	Support multi-protocol access to industrial or IoT systems
	Compact size
	Support PoE
	Bi-spectrum display
	Powerful web client
	Wi-Fi hotspot

Typical Applications	Monitoring power distribution cabinet
	Monitoring warehouse
	Monitoring production line

6.Product Figure and Explanation

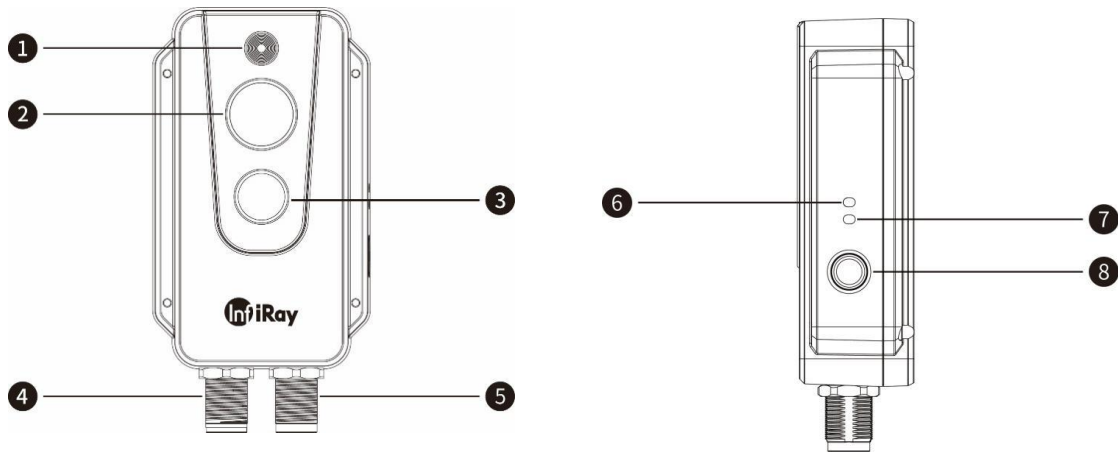

No.	Explanation
1	Fill light
2	Digital camera
3	Infrared lens
4	Ethernet and PoE cable interface
5	DC power supply and alarm input/output
6	Power LED light
7	Network LED light
8	Reset button

Table 6.1 Explanation of Product Appearance

7.Quick Start Guide

Please follow the steps:

1. After installing the thermal camera in the desired position, use the cable to connect the thermal camera and the computer normally. There are two power supply methods for AT20. Connect the device to the PoE port of the power supply through the M12 8-pin adapter cable or connect to the DC power supply through the M12 12-pin adapter cable. Connect AT20 to the network, and wait for 2 minutes after powering on. The power indicator light is steady blue and the network indicator light flashes green, indicating that the network connection is normal.
2. Modify the computer network segment to be the same with that of thermal camera. The specific path is "Control Panel"->"Network and Internet"->"Network and Sharing Center"->"Change Adapter Options"->"Ethernet"->" Properties"->"Internet Protocol Version 4 (TCP/IPv4)" - "Use the following IP address"-set the IP address to 192.168.1.xxx.
3. After the power is on for 30 minutes, the temperature measurement, monitoring and analysis can be carried out through the web terminal of the computer. For web instructions, please refer to AT20 Online Dual-spectrum Thermal Camera Web Client Operation Manual.

8.Product and Accessories List

Product and Accessories
AT20 online dual-spectrum thermal camera
44cm long M12 8-pin adapter cable
Fixing accessories (screws, mounting stickers)

Optional Accessories
M12 12-pin adapter cable & alarm input/output cable
front/rear mounting bracket

Table 8.1 Product and Accessories List

9. Mechanical Installation

The front and back of the thermal camera are equipped with mounting interfaces, which can be installed with screws after the holes are punched with the auxiliary stickers in the package. In addition, we also provide two optional forms of front and back installation.



WARNING

Do not use too long screws in case of damaging the thermal camera.

The maximum hole depth of the front shell is 10mm, and the maximum hole depth of the rear shell is 4mm.

It's normal that the thermal camera will generate heat during operation. In order to sufficiently dissipate the heat, it is suggested that the back shell of the thermal camera should be fixed on a metal object to minimize the temperature drift of the infrared detector in thermal camera.

9.1 Installing Shells with Screws

9.1.1 Installing Front Shell

As shown in Figure 9.1, please paste the sticker to the position to be installed, and then punch 4 $\Phi 2.5$ mounting holes according to the label on the sticker, and use 4 ST2.2 screws to install the front shell.

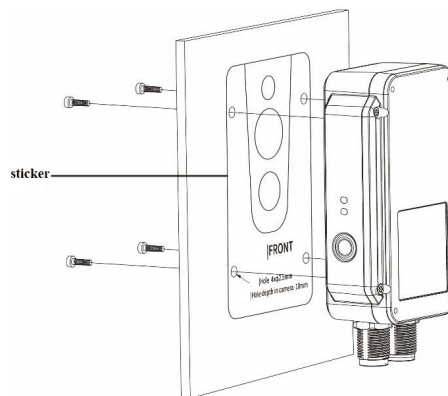

Figure 9.1 Front Shell Installation

9.1.2 Installing Rear Shell

As shown in Figure 9.2, please paste the sticker to the position to be installed, and then punch 4 $\Phi 2.5$ mounting holes according to the label on the sticker, and use 4 M2 screws to install the rear shell.

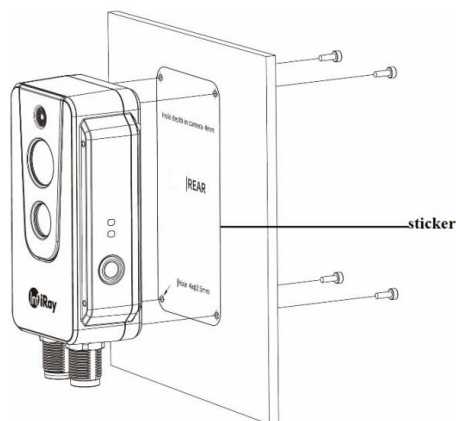

Figure 9.2 Rear Shell Installation

9.2 Front Mounting

There are four M4 threaded holes on the front mounting bracket for fixing.

Step 1 Install the front mounting bracket

As shown in Figure 9.3, connect the front mounting bracket and the thermal camera with ST2.2*8 self-tapping screws. The installation effect is shown in Figure 9.4.

Step 2 Punch holes

As shown in Figure 9.5, please paste the sticker to the position to be installed, and then punch four $\Phi 4.5$ mounting holes according to the label on the sticker.

Step 3 Install the thermal camera

As shown in Figure 9.5, use M4 screws to install the thermal camera to the designated location.

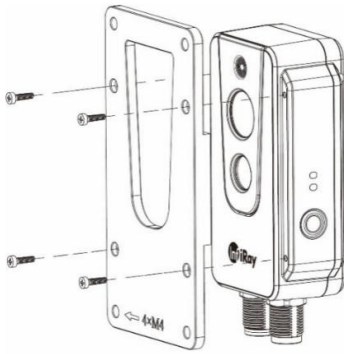

Figure 9.3



Figure 9.4

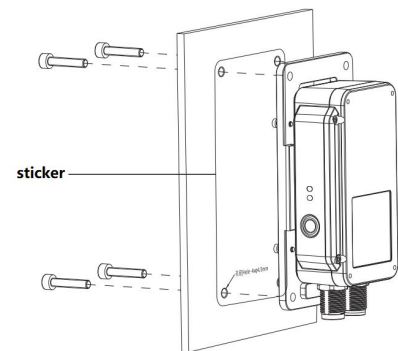

Figure 9.5

9.3 Rear Mounting

There are four M4 threaded holes on the rear mounting bracket for fixing.

Step 1 Install the rear mounting bracket

As shown in Figure 9.6, connect the rear mounting bracket and the thermal camera with ST2.2*8 self-tapping screws. The effect installation is shown in Figure 9.7.

Step 2 Punch holes

As shown in Figure 9.8, please paste the sticker to the position to be installed, and then punch four $\Phi 4.5$ mounting holes according to the label on the sticker.

Step 3 Install the thermal camera

As shown in Figure 9.8, use M4 screws to install the thermal camera to the designated location.

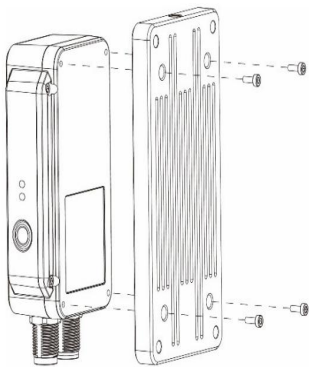

Figure 9.6

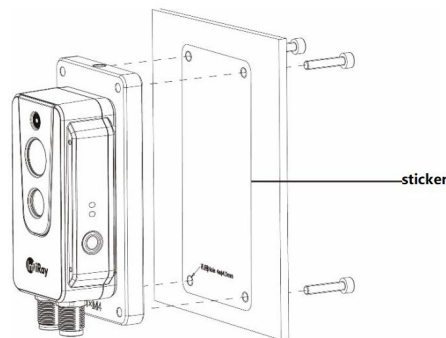

Figure 9.7

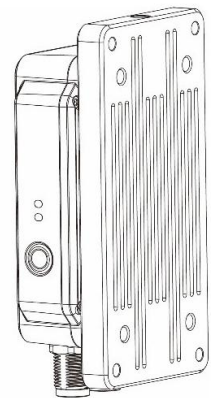

Figure 9.8

10. Alarm Input and Output

10.1 Alarm Input

Support 1 active alarm input (photoelectric isolation), and the input voltage range is 3~5.5V.

10.2 Alarm Output

Support 2 alarm outputs (switch value and photoelectric isolation), 3~25VDC, maximum 85mA.

11. Protocol Introduction

11.1 Modbus TCP

This camera supports Modbus TCP protocol for transmitting temperature measurement information.

M12 8-pin to RJ45 cable is required when using this protocol.

IP	Camera IP(default: 192.168.1.20)		
Port	1502		
Register Address	R/W	Length(word)	Data
0x0001	R	2	Version No., e.g.0x0102 0x0304 = V1.2.3.4
0x0003	R	1	
0x0004	R	1	
0x0005	R	1	
0x0006	R	1	
0x0007	R	2	the highest temperature of the entire frame, the actual temperature = (register value-2732) / 10.0
0x0009	R	2	the average temperature of the entire frame
0x000B	R	2	the lowest temperature of the entire frame
0x000D+N*4	R	1	Region attributes, Bit0: region validness Bit1~2: region type, box=0,line=1,point=2 Bit3: whether temperature alarm is on Bit4:whether to trigger an alarm
0x000E+N*4	R	1	the highest temperature in the region
0x000F+N*4	R	1	the average temperature in the region
0x0010+N*4	R	1	the lowest temperature in the region
*N: 0~15			

11.2 MQTT

AT20 supports the MQTT protocol, as defined below:

1. The server sends the subject.

AT20_IRAY

2. Set the configuration MQTT parameters through the Web interface, and enable the MQTT function. The configuration will be valid after saving and restarting. The camera will automatically connect to the MQTT

server after restarting.

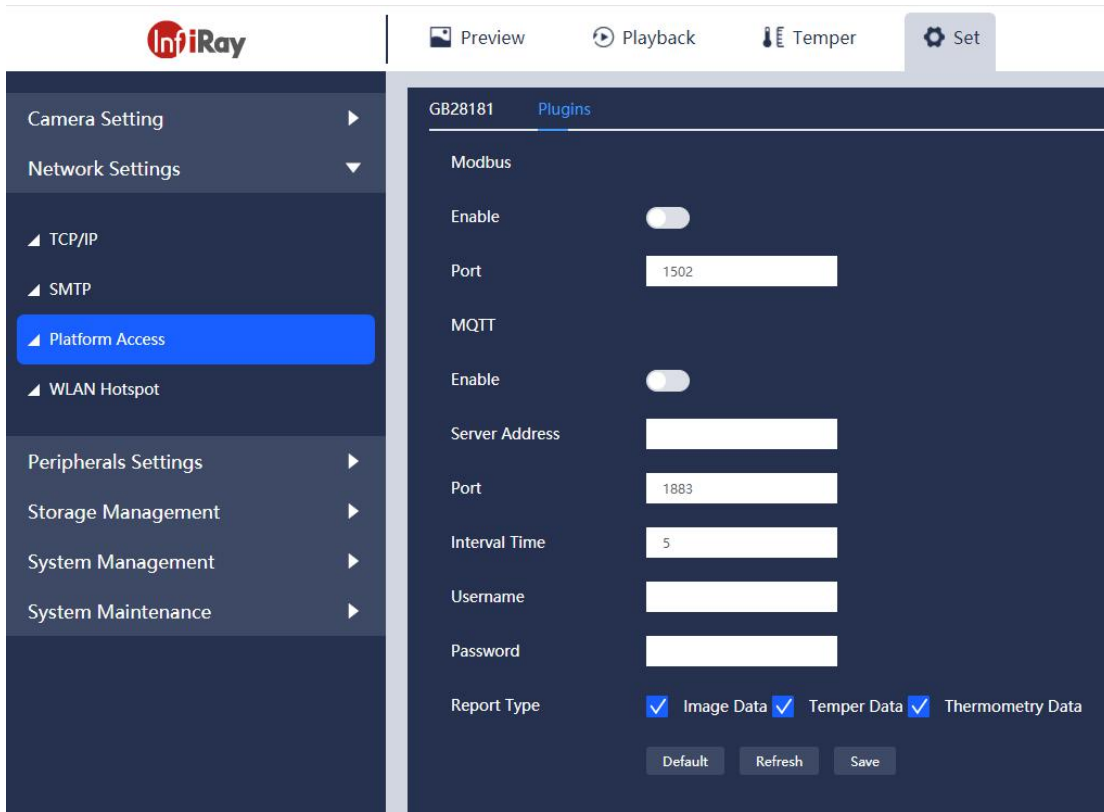

3. Data format is as follows:

Image data:

```
{
  "timestamp": "2021.4.9.15:52", #time stamp
  "ip": "192.168.1.21",          #camera IP
  "type": 0,                    #data type: 0-image 1-temperature 2-temperature measurement
  "resolution": "1280*720",     #visible light resolution
  "resolution": "1024*768",     #thermal resolution
  "formate": ".jpg",           #image format
  "image": "....."            # visible light image data base64 encode
  "ir_image": "....."         # thermal image data base64 encode
}
```

Temperature data:

```
{
  "timestamp": "2021.4.9.15:52", # time stamp
  "ip": "192.168.1.21",          #camera IP
```

```

"type": 1,          # data type: 0-image 1-temperature 2-temperature measurement
"unit": "C",        #Unit: °C
"data": "....."    # temperature data base64 encode
}

```

Temperature measurement data: temperature measurement function needs to be enabled in Web interface.

```

{
"timestamp": "2021.4.9.15:52", # time stamp
"ip": "192.168.1.21",          # camera IP
"type": 2,                     # data type: 0-image 1-temperature 2-temperature measurement
"subnetmask": "255.255.255.0", #subnet mask
"gateway": "192.168.1.1",      #gateway
"mac": "86:5D:55:0B:A9:74",    #MAC address
"uptime":33,                   #boot time
"version": "V0.2.7",           #software version
"airTemp": 25,                 #air temperature(°C)
"airtransmissivit": 1,        #air transmittance
"distance": 3,                 #distance(m)
"emissivity": 0.95,           # emissivity
"reflectemp": 25,             # reflection temperature(°C)
"maxtemp": 45.6,              #maximum temperature of frame(°C)
"mintemp": 44.9,              # minimum temperature of frame(°C)
"avgtemp": 45.3,              #average temperature of frame(°C)
"list": [{                    # 16 data in the temperature measurement area, enable=1 is valid
  "index": 0,                  # temperature index
  "enable":1,                  #enable temperature measuring or not
  "type": 0,                   #type: 0- rectangle 1-line 2-point
  "x0": 67,                    #start: x value
  "y0": 61,                    #start: y value
  "x1": 125,                   #end: x value
  "y1": 98,                    #end: y value
  "maxTemp": 45.5,             # maximum temperature of the region(°C)
  "minTemp": 45,               # minimum temperature of the region(°C)
  "avgTemp": 45.3# average temperature of the region(°C)
}, {
  "index": 1,

```

```
"enable":0,  
"type": 0,  
"x0": 0,  
"y0": 0,  
"x1": 0,  
"y1": 0,  
"maxTemp": 0,  
"minTemp": 0,  
"avgTemp": 0  
}, {  
"index": 2,  
"enable":0,  
"type": 0,  
"x0": 0,  
"y0": 0,  
"x1": 0,  
"y1": 0,  
"maxTemp": 0,  
"minTemp": 0,  
"avgTemp": 0  
}, {  
"index": 3,  
"enable":0,  
"type": 0,  
"x0": 0,  
"y0": 0,  
"x1": 0,  
"y1": 0,  
"maxTemp": 0,  
"minTemp": 0,  
"avgTemp": 0  
}, {  
"index": 4,  
"enable":0,  
"type": 0,  
"x0": 0,  
"y0": 0,  
"x1": 0,
```

```
"y1": 0,
"maxTemp": 0,
"minTemp": 0,
"avgTemp": 0
}, {
"index": 5,
"enable":0,
"type": 0,
"x0": 0,
"y0": 0,
"x1": 0,
"y1": 0,
"maxTemp": 0,
"minTemp": 0,
"avgTemp": 0
}, {
"index": 6,
"enable":0,
"type": 0,
"x0": 0,
"y0": 0,
"x1": 0,
"y1": 0,
"maxTemp": 0,
"minTemp": 0,
"avgTemp": 0
}, {
"index": 7,
"enable":0,
"type": 0,
"x0": 0,
"y0": 0,
"x1": 0,
"y1": 0,
"maxTemp": 0,
"minTemp": 0,
"avgTemp": 0
}, {
```

```
"index": 8,  
"enable":0,  
"type": 0,  
"x0": 0,  
"y0": 0,  
"x1": 0,  
"y1": 0,  
"maxTemp": 0,  
"minTemp": 0,  
"avgTemp": 0  
}, {  
"index": 9,  
"enable":0,  
"type": 0,  
"x0": 0,  
"y0": 0,  
"x1": 0,  
"y1": 0,  
"maxTemp": 0,  
"minTemp": 0,  
"avgTemp": 0  
}, {  
"index": 10,  
"enable":0,  
"type": 0,  
"x0": 0,  
"y0": 0,  
"x1": 0,  
"y1": 0,  
"maxTemp": 0,  
"minTemp": 0,  
"avgTemp": 0  
}, {  
"index": 11,  
"enable":0,  
"type": 0,  
"x0": 0,  
"y0": 0,
```

```
"x1": 0,
"y1": 0,
"maxTemp": 0,
"minTemp": 0,
"avgTemp": 0
}, {
  "index": 12,
  "enable":0,
  "type": 0,
  "x0": 0,
  "y0": 0,
  "x1": 0,
  "y1": 0,
  "maxTemp": 0,
  "minTemp": 0,
  "avgTemp": 0
}, {
  "index": 13,
  "enable":0,
  "type": 0,
  "x0": 0,
  "y0": 0,
  "x1": 0,
  "y1": 0,
  "maxTemp": 0,
  "minTemp": 0,
  "avgTemp": 0
}, {
  "index": 14,
  "enable":0,
  "type": 0,
  "x0": 0,
  "y0": 0,
  "x1": 0,
  "y1": 0,
  "maxTemp": 0,
  "minTemp": 0,
  "avgTemp": 0
```

```
}, {  
  "index": 15,  
  "enable":0,  
  "type": 0,  
  "x0": 0,  
  "y0": 0,  
  "x1": 0,  
  "y1": 0,  
  "maxTemp": 0,  
  "minTemp": 0,  
  "avgTemp": 0  
}]  
}
```

12. Protocol Introduction

12.1 Modbus TCP

This camera supports Modbus TCP protocol for transmitting temperature measurement information.

M12 8-pin to RJ45 cable is required when using this protocol.

IP	Camera IP(default: 192.168.1.20)		
Port	1502		
Register Address	R/W	Length (word)	Data
0x0001	R	2	Version No., e.g.0x0102 0x0304 = V1.2.3.4
0x0003	R	1	
0x0004	R	1	
0x0005	R	1	
0x0006	R	1	
0x0007	R	2	the highest temperature of the entire frame, the actual temperature = (register value-2732) / 10.0
0x0009	R	2	the average temperature of the entire frame
0x000B	R	2	the lowest temperature of the entire frame
0x000D+N*4	R	1	Region attributes, Bit0: region validness Bit1~2: region type, box=0,line=1,point=2 Bit3: whether temperature alarm is on Bit4:whether to trigger an alarm
0x000E+N*4	R	1	the highest temperature in the region
0x000F+N*4	R	1	the average temperature in the region
0x0010+N*4	R	1	the lowest temperature in the region
*N: 0~15			

13. Technical Data

Detector Data	
Detector Type	VOx, Uncooled FPA detector
Spectral Range	8~14 μ m
Pixel	12 μ m

Imaging and Optical Data		
Infrared	Resolution	256×192
	NETD	40mK
	Frequency	30Hz
	Lens	3.2mm
	FOV	56°×42°
	Focusing	non-focusing
Visible Light	Visible Light Pixels	2 million (SC2310)
	FOV	72°×61°
	Fill Light	LED

Temperature Measurement	
Object Temperature Range	-20~550 $^{\circ}$ C
Accuracy	\pm 2 $^{\circ}$ C or \pm 2%
Point/Line/Area	maximum 16 points/lines/areas
Palette	18 palettes are available

<p>Environment Variable Correction</p>	<p>distance, atmospheric temperature, emissivity, reflection temperature, atmospheric transmittance</p>
--	---

<p style="text-align: center;">Alarm</p>	
<p>Alarm Function</p>	<p>The highest temperature, lowest temperature and average temperature in all temperature measurement points, temperature measurement areas and lines can be configured with separate alarm outputs.</p>
<p>Alarm Input/Output</p>	<p>1 alarm input (photoelectric isolation, 3~5.5V); 2 alarm output (photoelectric isolation, 3~25VDC, maximum 85mA) Other alarms: save image/video, sending file (FTP), email (SMTP), and flash alarm;</p>

Image transmission		
Image Stream	Image Stream Format	H.264/H.265
	Resolution	visible light 1080P; infrared support super resolution up to 4X, Max 1024×768
	Image Mode	thermal image, visible image, fusion, DDE, and parallel display of visible light images are supported.
	Frequency Adjustment	supported
Data Stream	Data Stream Transmission	Visible and thermal images, temperature stream, adjustable frequency
Image Storage	Storage Medium	built-in 32GB storage
	Storage Mode	store thermal images and visible images simultaneously.
	File Format	JPG, MP4
	Storage Form	local storage; connected to monitoring systems, such as NVR.

Ethernet	
Ethernet Functions	control, imaging and power supply
Ethernet Connector Type	RJ45/ hotspot of thermal camera
Ethernet Power Supply	PoE is supported
Network Protocol	TCP,UDP,RTSP,HTTP,SMTP
Interface Protocol	ONVIF,GB28181,Modbus TCP,MQTT

Typical Power Supply	
External Power	12~30V DC
PoE	IEEE 802.3af
Power Consumption	≤2W

Physical Data	
Dimension	109×55.9×29.5mm
Weight	170g
Housing Material	Front shell is plastic and rear shell is aluminium alloy. .

Environmental Data	
Ingress Protection	IP67
Operating Temperature Range	-10~50℃
Storage Temperature Range	-40~70℃
Humidity	≤95% (no condensation)
EMC	IEC 61000-4-2(anti-interference) IEC 61000-4-3(anti-radiation)
Shock	25G, IEC68-2-29
Vibration	2G, IEC68-2-6

Others	
Certification	CE/FCC/RoHS
SDK	Cross-platform SDK that supports secondary development of customers.
External Interface	M12 A type 8-pin, including 10M / 100M adaptive Ethernet port and PoE power supply; M12 A type 12-pin, including DC power supply, alarm input and output;

Table 13.1 AT20 Performance Parameters

14.Pin Configuration for Interfaces

14.1 Ethernet Pin Configuration (8pin)

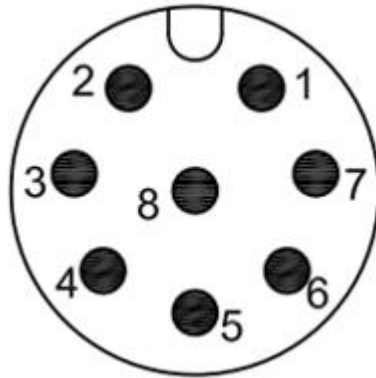

Pin	Configuration	Pin	Configuration
1	TX+	5	PD+
2	TX-	6	PD+
3	RX+	7	PD-
4	RX-	8	PD-

14.2 Power Pin Configuration (12pin)



Pin	Configuration	Pin	Configuration
1	Power +	7	ALARM_POWER2
2	Power +	8	ALARM_OUT2
3	Power Ground	9	ALARM_IN+
4	Power Ground	10	ALARM_IN-
5	ALARM_POWER1	11	NC
6	ALARM_OUT1	12	NC

15.Mechanical Drawings

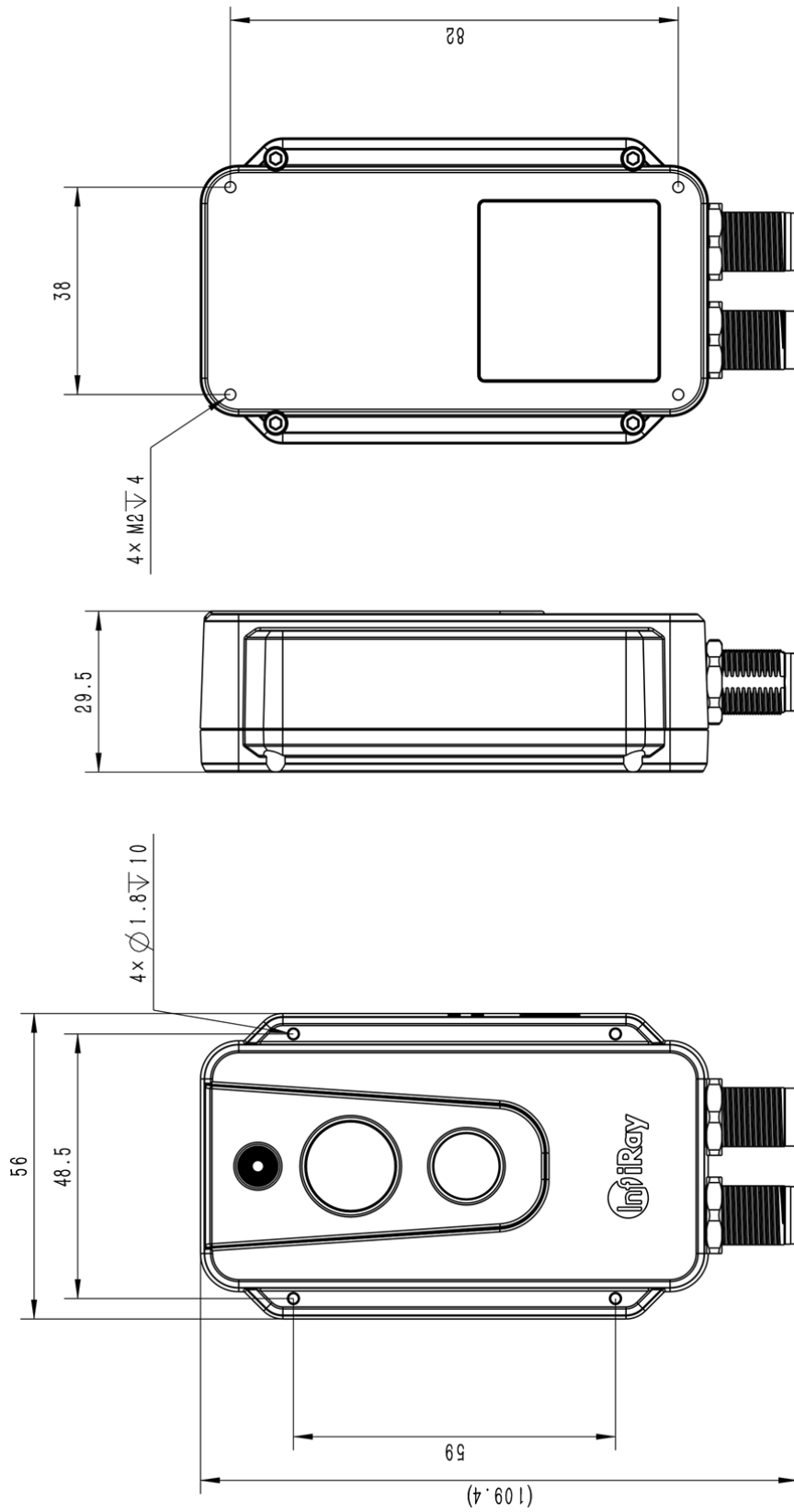

16.Common Troubleshooting

Troubles	Possible Cause	Solutions
Camera cannot be started.	The supply voltage exceeds the normal working supply voltage range.	Check whether the power supply voltage is between 12 and 24V
	The power connector is loose.	Check whether the power cable is connected
Web cannot be logged in.	IP setting is wrong.	Manually configure the computer address to the 192.168.1.XX
Image is stuck.	Network cable connection is loose.	After checking the network cable connection, restart the web.

17. Download Software and Update Firmware

17.1 Download Software

1. Visit our official website: www.infiray.com, and enter "Service Support"->"Product Support Center" to find "AT20 online dual-spectrum temperature measurement thermal imaging camera". Click to enter "Client", and you can download industrial temperature monitoring System "IRT_VMS_Win64.exe".
2. Follow the instructions to install IRT_VMS on PC.
3. After the installation is completed, there is no need to restart the computer, and functions such as device management, preview, alarm, temperature measurement, user management and system configuration can be realized.

17.2 Update Firmware

If the firmware of the device needs to be updated, please call the technical support hotline +86 400-883-0800 and update the firmware under the guidance of the product application engineer.

The update steps are as follows:

1. Log in to AT20 web. The default IP is 192.168.1.20. Before logging in, make sure that the computer IP and the device are in the same network segment (192.168.1.xx).
2. Click "Settings"->"System Maintenance"->"System Upgrade" in turn.
3. Click "Import" and select the firmware file to be upgraded.
4. Click "Format" and "Upgrade" in turn to finish the firmware update.

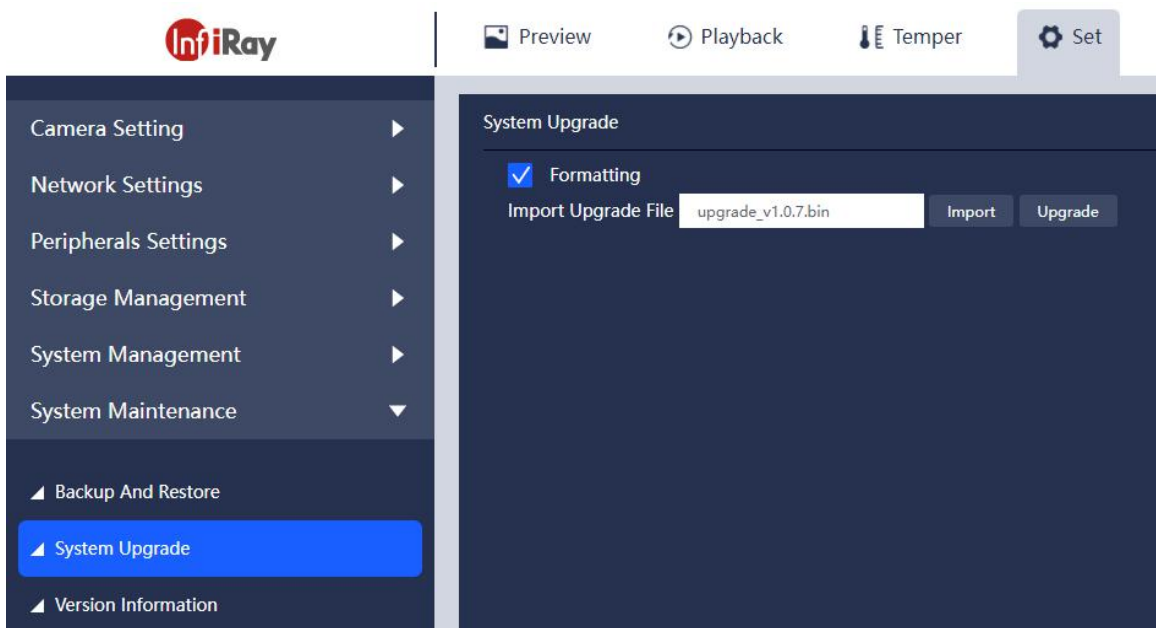

18.Cleaning Thermal Camera

18.1 Cleaning Camera Housing, Cables and Other Items

Camera Housing, Cables and Other Items	
Liquids	One of the following liquids can be used. <ol style="list-style-type: none">1.Warm water2.A Weak detergent solution
Cleaning Tools	A soft cloth
Cleaning Procedure	Please follow this procedure: <ol style="list-style-type: none">1.Soak a soft cloth in the liquid.2.Twist the cloth to remove excess liquid.3.Clean the camera parts with the cloth.

18.2 Cleaning Infrared Lens

Cleaning Infrared Lens	
Liquids	<p>One of the following liquids can be used.</p> <ol style="list-style-type: none">1. Commercial lens cleaning liquid with more than 30% isopropyl alcohol.2. 96% ethyl alcohol (C₂H₅OH).
Cleaning Tools	Dustless cloth, cotton wool
Cleaning Procedure	<p>Please follow this procedure (Take dustless cloth as an example).</p> <ol style="list-style-type: none">1. Soak the dustless cloth in the liquid.2. Gently wipe the lens with the dustless cloth



CAUTION

The dustless cloth or cotton wool should be used one time only.

Appendix A Emissivity of Common Materials

Material	Temperature (°C)	Emissivity
Water	0~100	0.95~0.98
Soil(dry)	20	0.92
Soil(wet)	20	0.95
Woods	17	0.962
Sand	20	0.9
Sandstone	19	0.909~0.935
PVC plastic	70	0.93
Asphalt	20	0.967
Paint	70	0.92~0.94
Wallpaper	20	0.85~0.90
Cloth	20	0.98
Concrete	20	0.92
Pavement surface	5	0.974
Smooth porcelain	20	0.92
Ceramic tile	17	0.94
Gypsum	17	0.86
Bricks	35	0.94
Hard rubber	0~100	0.89
Charcoal	20~400	0.95~0.97
Granite(rough)	20	0.879
Cold rolled steel	70	0.09
Oxidized steel	50	0.88
Copper	20	0.07
Oxidized copper	50	0.6~0.7

Worth comes from Service

24h Hotline:
400-998-3088

Technical Support

Hotline:
400-883-0800

Customized Services